

Gas/liquid sampler

The Gas/Liquid sampler is designed to measure gas/liquid flow and bring back samples from a subsea leakage.

The lower part of the funnel can be separated from the gas sampler, in order to get better access in confined spaces.

It was also designed to be operated by a work class ROV

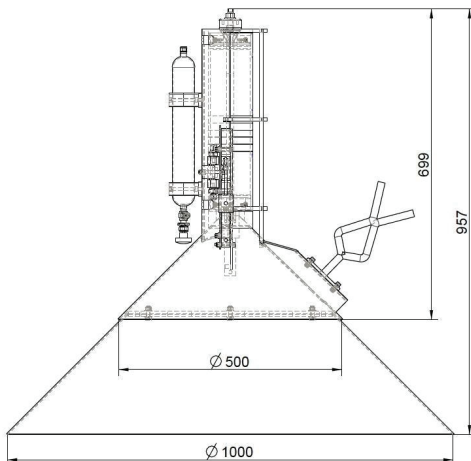

Water depth:	3000 m.
Max pressure:	200 bar
Typical pressure:	50 bar